

10000W Axial Leaded Transient Voltage Suppressors

Features

- Peak power dissipation 10000W @10 x 1000 us Pulse
- Low profile package.
- Excellent clamping capability.
- Glass passivated junction.
- Fast response time: typically less than 1ps from 0 Volts to BV min
- Typical I_R less than 5uA when V_{BR} min above 24V.
- IEC 61000-4-2 ESD 30KV(Air), 30KV(Contact)
- ESD protection of data lines in accordance with IEC 61000-4-2
- EFT protection of data lines in accordance with IEC 61000-4-4
- Halogen free and RoHS compliant
- Lead-free finish

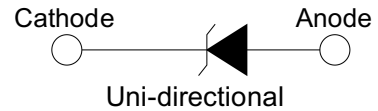
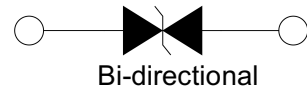
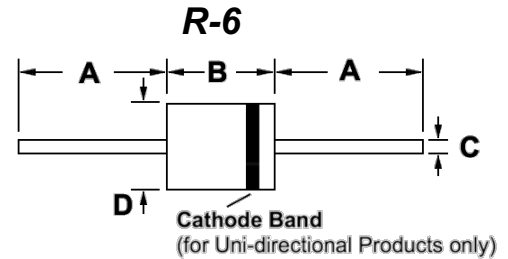

Mechanical Characteristics

- CASE: R-6 Molded Plastic
- Mounting Position: Any
- Polarity: by cathode band denotes uni-directional device, none cathode band denotes bi-directional device.
- Terminal: Solder plated

REF.	DIMENSIONS			
	Millimeters		Inches	
	Min.	Max.	Min.	Max.
A	25.4	---	1.000	---
B	8.6	9.5	0.34	0.375
C	1.2	1.3	0.048	0.052
D	8.6	9.5	0.340	0.375

Maximum Ratings and Characteristics @ 25°C Ambient Temperature (unless otherwise noted)

Parameter	Symbol	Value	Units
Peak Pulse Power Dissipation on 10/1000 us Waveform (Note 1, FIG.1)	P_{PPM}	Min 10000	W
Power Dissipation on Infinite Heat Sink at $T_L=75^\circ\text{C}$	P_D	8.0	W
Peak Pulse Current of on 10/1000us Waveform (Note 1, FIG.3)	I_{PPM}	See Table 1	A
Peak Forward Surge Current, 8.3ms Single Half Sine-Wave (Note 2)	I_{FSM}	400	A
Operating Junction Temperature Range	T_J	-55 to 150	$^\circ\text{C}$
Storage Temperature Range	T_{STG}	-55 to 150	$^\circ\text{C}$

Notes:

1. Non-repetitive current pulse, per Fig.3 and derated above $T_A=25^\circ\text{C}$ per Fig.2.
2. Measured on 8.3ms single half sine-wave, or equivalent square wave, for Unidirectional device only.

Electrical Specification (T_A=25@25°C unless otherwise specified)

Type Number		Reverse Stand-Off Voltage	Breakdown Voltage Min. @I _T	Breakdown Voltage Max. @ I _T	Test Current	Maximum Clamping Voltage @I _{PP}	Peak Pulse Current	Reverse Leakage @V _{RMW}
(Uni)	(Bi)	V _{RMW} (V)	V _{BR MIN} (V)	V _{BR MAX} (V)	I _T (mA)	V _C (V)	I _{PP} (A)	I _R (μA)
10KP17A	10KP17CA	17.0	18.90	20.90	5	27.6	365.9	150
10KP18A	10KP18CA	18.0	20.00	22.10	5	29.2	345.9	100
10KP20A	10KP20CA	20.0	22.20	24.50	5	32.4	311.7	50
10KP22A	10KP22CA	22.0	24.40	26.90	5	35.5	284.5	15
10KP24A	10KP24CA	24.0	26.70	29.50	5	38.9	259.6	5
10KP26A	10KP26CA	26.0	28.90	31.90	5	42.1	239.9	5
10KP28A	10KP28CA	28.0	31.10	34.40	5	45.4	222.5	5
10KP30A	10KP30CA	30.0	33.30	36.80	5	48.4	208.7	5
10KP33A	10KP33CA	33.0	36.70	40.60	5	53.3	189.5	5
10KP36A	10KP36CA	36.0	40.00	44.20	5	58.1	173.8	5
10KP40A	10KP40CA	40.0	44.40	49.10	5	64.5	156.6	5
10KP43A	10KP43CA	43.0	47.80	52.80	5	69.4	145.5	5
10KP45A	10KP45CA	45.0	50.00	55.30	5	72.7	138.9	5
10KP48A	10KP48CA	48.0	53.30	58.90	5	77.4	130.5	5
10KP51A	10KP51CA	51.0	56.70	62.70	5	82.4	122.6	5
10KP54A	10KP54CA	54.0	60.00	66.30	5	87.1	116.0	5
10KP58A	10KP58CA	58.0	64.40	71.20	5	93.6	107.9	5
10KP60A	10KP60CA	60.0	66.70	73.70	5	96.8	104.3	5
10KP64A	10KP64CA	64.0	71.10	78.60	5	103.0	98.1	5
10KP70A	10KP70CA	70.0	77.80	86.00	5	113.0	89.4	5
10KP75A	10KP75CA	75.0	83.30	92.10	5	121.0	83.5	5
10KP78A	10KP78CA	78.0	86.70	95.80	5	126.0	80.2	5
10KP85A	10KP85CA	85.0	94.40	104.00	5	137.0	73.7	5
10KP90A	10KP90CA	90.0	100.00	111.00	5	146.0	69.2	5
10KP100A	10KP100CA	100.0	111.00	123.00	5	162.0	62.3	5
10KP110A	10KP110CA	110.0	122.00	135.00	5	177.0	57.1	5
10KP120A	10KP120CA	120.0	133.00	147.00	5	193.0	52.3	5
10KP130A	10KP130CA	130.0	144.00	159.00	5	209.0	48.3	5
10KP150A	10KP150CA	150.0	167.00	185.00	5	243.0	41.6	5
10KP160A	10KP160CA	160.0	178.00	197.00	5	259.0	39.0	5
10KP170A	10KP170CA	170.0	189.00	209.00	5	275.0	36.7	5
10KP180A	10KP180CA	180.0	200.00	221.00	5	289.0	34.9	5
10KP190A	10KP190CA	190.0	211.00	233.00	5	310.0	32.6	5
10KP200A	10KP200CA	200.0	222.00	246.00	5	329.2	30.7	5
10KP210A	10KP210CA	210.0	233.00	258.00	5	349.5	28.9	5
10KP220A	10KP220CA	220.0	244.00	270.00	5	371.1	27.2	5
10KP250A	10KP250CA	250.0	277.00	306.00	5	425.0	23.8	2

※ For Bi-directional type having V_{RMW} of 20 Volts and less, the I_R limit is double.

※ For parts without A, the V_{BR} is ± 10% and V_C is 5% higher than with A parts.

I-V Curve Characteristics

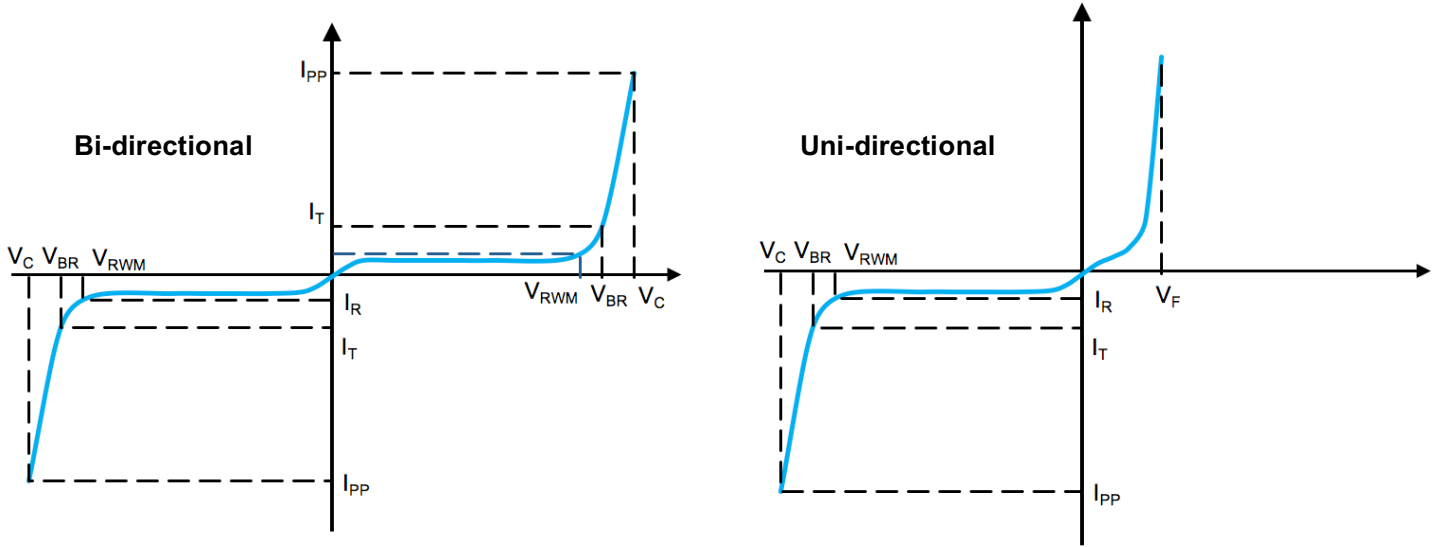

- P_{PPM}** Peak Pulse Power Dissipation - Max power dissipation
- V_{RWM}** Reverse Stand-off Voltage - Maximum voltage that can be applied to TVS without operation
- V_{BR}** Breakdown Voltage – Maximum voltage that flows through the TVS at a specified current (I_T)
- V_C** Clamping Voltage – Peak voltage measured across the TVS at a specified I_{PPM} (peak impulse current)
- I_R** Reverse Leakage Current – Current measured at V_R
- V_F** Forward Voltage Drop for Uni-directional

Ratings and Characteristic Curves ($T_A=25^\circ\text{C}$ unless otherwise noted)

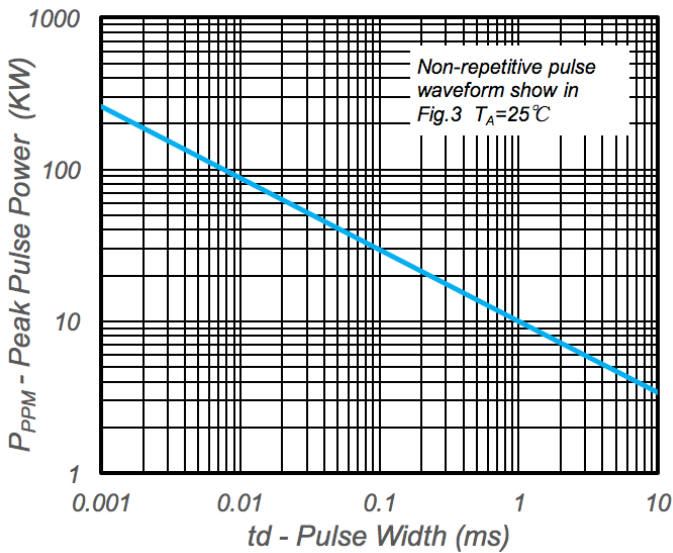

Fig.1 - Peak Pulse Power Rating

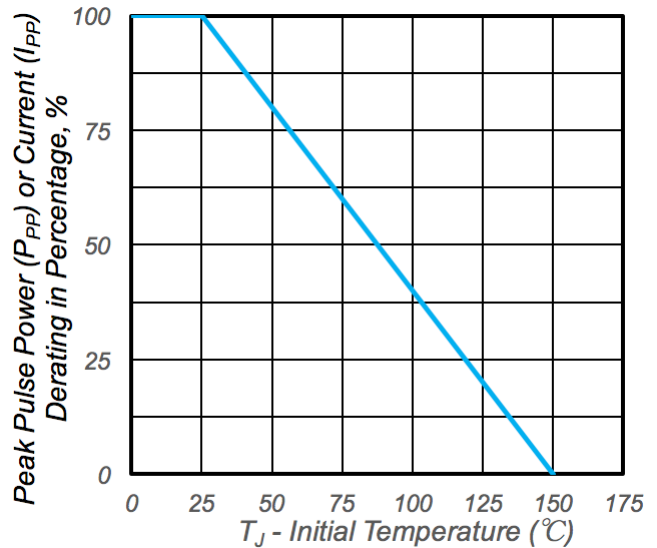

Fig.2 - Pulse Derating Curve

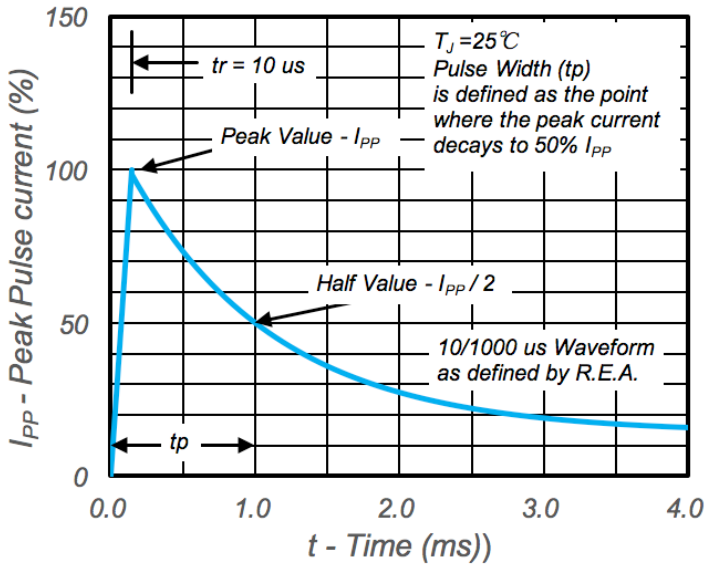

Fig.3 – Pulse Waveform

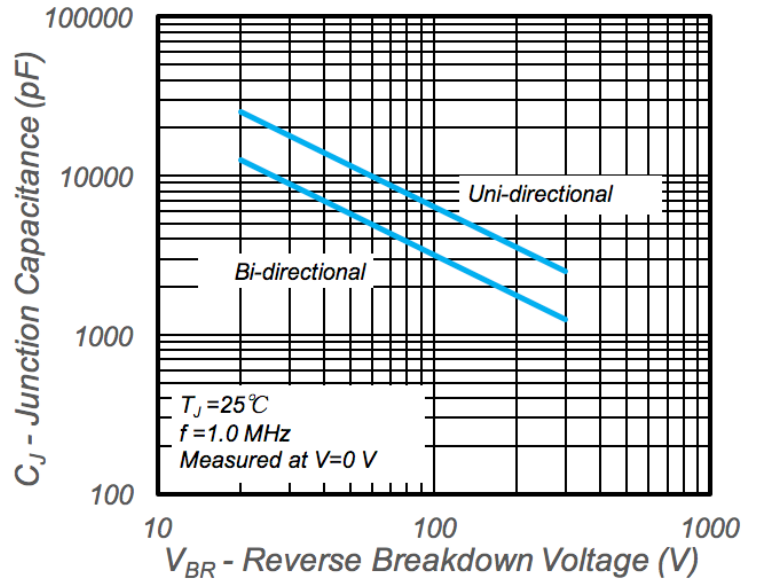

Fig.4 - Typical Junction Capacitance